

**SURGE ARRESTERS – CLASS I+II**

**G50/275(-S)/4P**

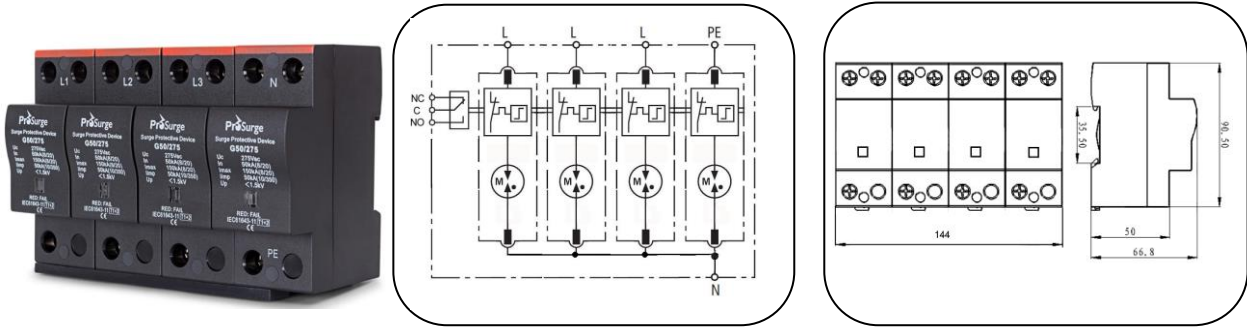

Basic circuit diagram

Dimension drawing

Type1+2 surge arrester designed for low-voltage power supply system protection against surges and even direct lightning strikes at the boundaries from lightning protection zone 0A-2 and higher.

- Encapsulated Hybrid spark gap with MOV technology to guarantee reliability in rugged environment
- Comply with IEC/EN61643-11, IEEE C62.41-1991, IEEE C62.41-2002, IEEE C62.45-2002, IEEE C62.62-2010 standard, surge arrester for use in TT and TN-S systems ("3+1" circuit) 220/380VAC 3Phase 4 Pole 50-60Hz
- Discharge capacity limp 50KA10/350 with Low voltage protection level

With remote signaling contact and failure indicator optional		G50/275(-S)/4P
In accordance with		IEC/EN61643-11:2011; UL1449-4th
Category IEC/VDE		I+ II / B+C
Max. continuous operating voltage (V)	AC	440
Nominal discharge current(8/20)	In	50kA
Max. discharge current(8/20)	Imax	150kA
Lightning impulse current (10/350)	Iimp	50kA
Voltage protection level	@1.2/50	<2.5kV
Let Through Voltage	3kA/6kV	<1kV
Response time		≤25 ns
short-circuit current rating (Iscrr) & follow current interrupt rating (Ifi)		Iscrr =50kArms ; Ifi≥10kArms@255Vac
TOVs with stand		440V/120min
Backup fuse(only required if not already provided in mains)		500A gL/gG
Operating temperature range		- 40°C ~ + 80°C
Cross-section of connection wire		Single-strand 35mm <sup>2</sup> ; multi-strand 25mm <sup>2</sup>
Mounting		35mm DIN-rail in accordance with EN 50022/DIN46277-3
Enclosure material		thermoplastic;UL94 V-0 / Metal
Degree of protection		IP20
Installation width		8 modules, DIN 43880
Thermal disconnecter		Internal red - failure
Remote alarm contact		Optional(For External LED and Alarm)
Approvals, Certifications		CE
<b>Additional data for Remote Alarm Contacts</b>		
Remote alarm contact type		Isolated Form C
Switching capability Un/In		AC: 250V/0.5A DC: 250V/0.1A; 125V/0.2A; 75V/0.5A
Max. Size of connecting wire		Max. 1.5mm <sup>2</sup> (or # 16AWG)

